

PROJECT: _____	UNIT TAG: _____	QUANTITY: _____
REPRESENTATIVE: _____	TYPE OF SERVICE: _____	DATE: _____
ENGINEER: _____	SUBMITTED BY: _____	DATE: _____
CONTRACTOR: _____	APPROVED BY: _____	DATE: _____
	ORDER NO.: _____	DATE: _____

CUE 3X380-500V IP55 45KW 90A/8

CUE



Product photo could vary from the actual product

Conditions of Service	Pump Data	Motor Data
Flow: _____	Maximum ambient temperature: 113 °F	Rated voltage: 380 - 440 / 441 - 500 V
Head: _____	Approvals: CE, CULUS, C-TICK	Main frequency: 60 Hz
Efficiency: _____	Product number: 96754729	Enclosure class: IP55
Liquid: _____		Motor protection: YES
Temperature: _____		Thermal protection: external
NPSH required: _____		
Viscosity: _____		
Specific Gravity: _____		

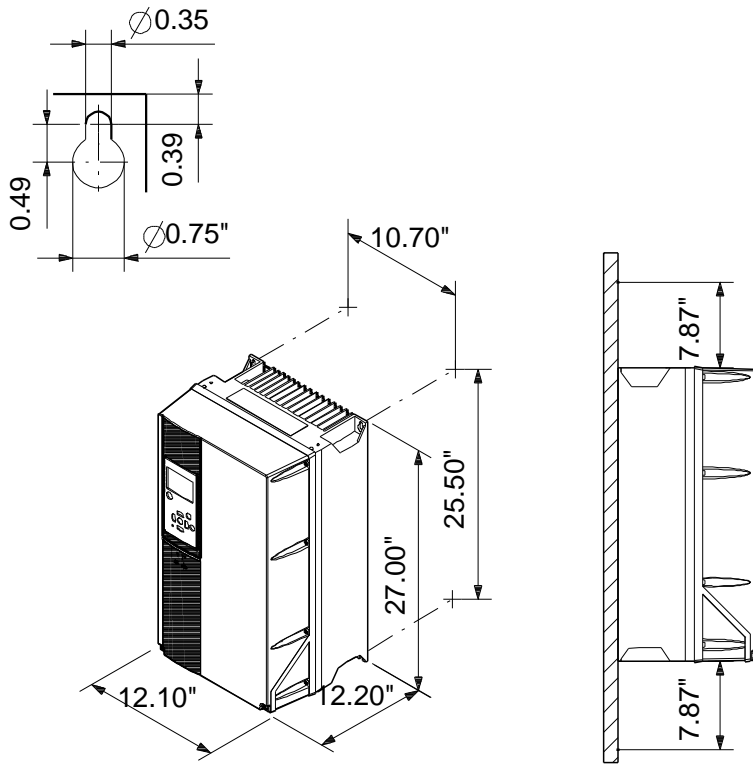

Count	Description
-------	-------------

1	CUE 3X380-500V IP55 45KW 90A/8
---	--------------------------------



Product photo could vary from the actual product

Product No.: [96754729](#)

CUE is a complete range of external frequency converters designed for speed control of a wide range of Grundfos pumps. CUE has a built-in PI controller and offers the same functionality and user-interface as Grundfos E-pumps. CUE solutions can thus be seen as an extension to the E-pump range.

By choosing a CUE-solution, you will get the following benefits:

- Grundfos E-pump functionality and user-interface
- application- and pump-family-related functions
- increased comfort compared to fixed-speed pumps
- very easy installation and commissioning compared to standard frequency converters
- speed control of pumps up to 250 kW
- speed control of pumps installed in potentially explosive environments.

CUE offers the following inputs and output:

- RS-485 GENIbus
- an analog 0-10 V input for external setpoint
- an analog 0/4-20 mA input for sensor
- four digital inputs for various functions, for instance external start/stop
- two signal relays (C/NO/NC).

Accessories:

Input/output add-on board

Provides additional input:

- one 0/4-20 mA analog input for an additional sensor
- one 0-20 mA analog output
- two inputs for Pt100/Pt1000 temperature sensors, for instance for bearing monitoring.

Motor filters:

For reduction of dU/dt and peak voltages to the motor windings and for reduction of the acoustic noise generated in the motor, a number of motor filters are offered:

- dU/dt filters , 11-250 kW
- Sine wave filters, 0.55-250 kW.

Technical:

Approvals on nameplate: CE, CULUS, C-TICK

Installation:

Range of ambient temperature: 32 .. 113 °F

Relative humidity: 5-95 %

Electrical data:

Rated power - P2: 60 HP

Main frequency: 60 Hz

Rated voltage: 3 x 380 - 440 / 441 - 500 V

WASCON

SALES and SERVICE

Company name: WASCON Inc.
Created by:
Phone: (931) 823 1388
Date: 8/7/2019

Count	Description
	Rated current: 90-80 A Maximum current consumption: 90 A Efficiency at full load: 98 % Enclosure class (IEC 34-5): IP55
	Others: Net weight: 99.2 lb Custom tariff no.: 8537.10.6000

Description	Value
General information:	
Product name:	CUE 3X380-500V IP55 45KW 90A/8
Product No.:	96754729
EAN:	5700838636376
Technical:	
Approvals on nameplate:	CE, CULUS, C-TICK
Installation:	
Range of ambient temperature:	32 .. 113 °F
Relative humidity:	5-95 %
Mounted on:	Wall
Electrical data:	
Rated power - P2:	60 HP
Main frequency:	60 Hz
Rated voltage:	3 x 380 - 440 / 441 - 500 V
Rated current:	90-80 A
Maximum current consumption:	90 A
Efficiency at full load:	98 %
Enclosure class (IEC 34-5):	IP55
Motor protection:	YES
Thermal protec:	external
Cable length:	150/300 m
Others:	
Net weight:	99.2 lb
Custom tariff no.:	8537.10.6000

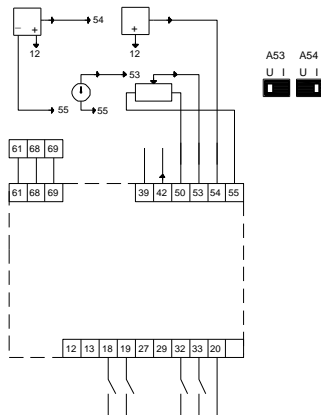
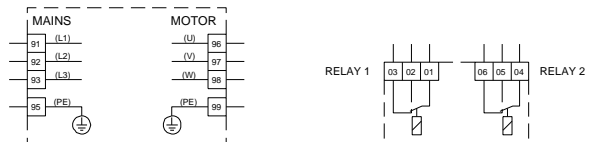
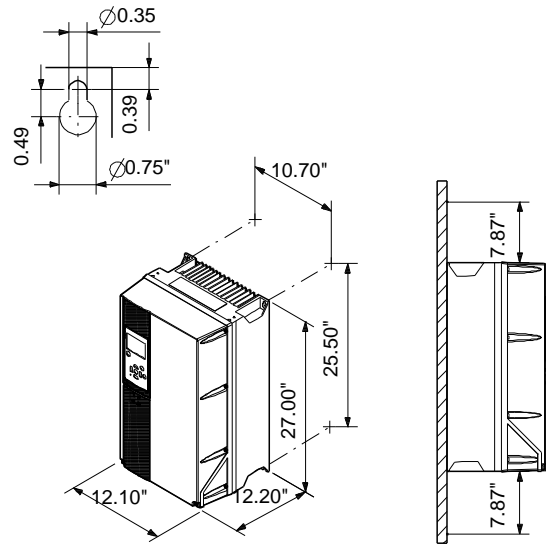

96754729 CUE 3X380-500V IP55 45KW 90A/8 60 Hz

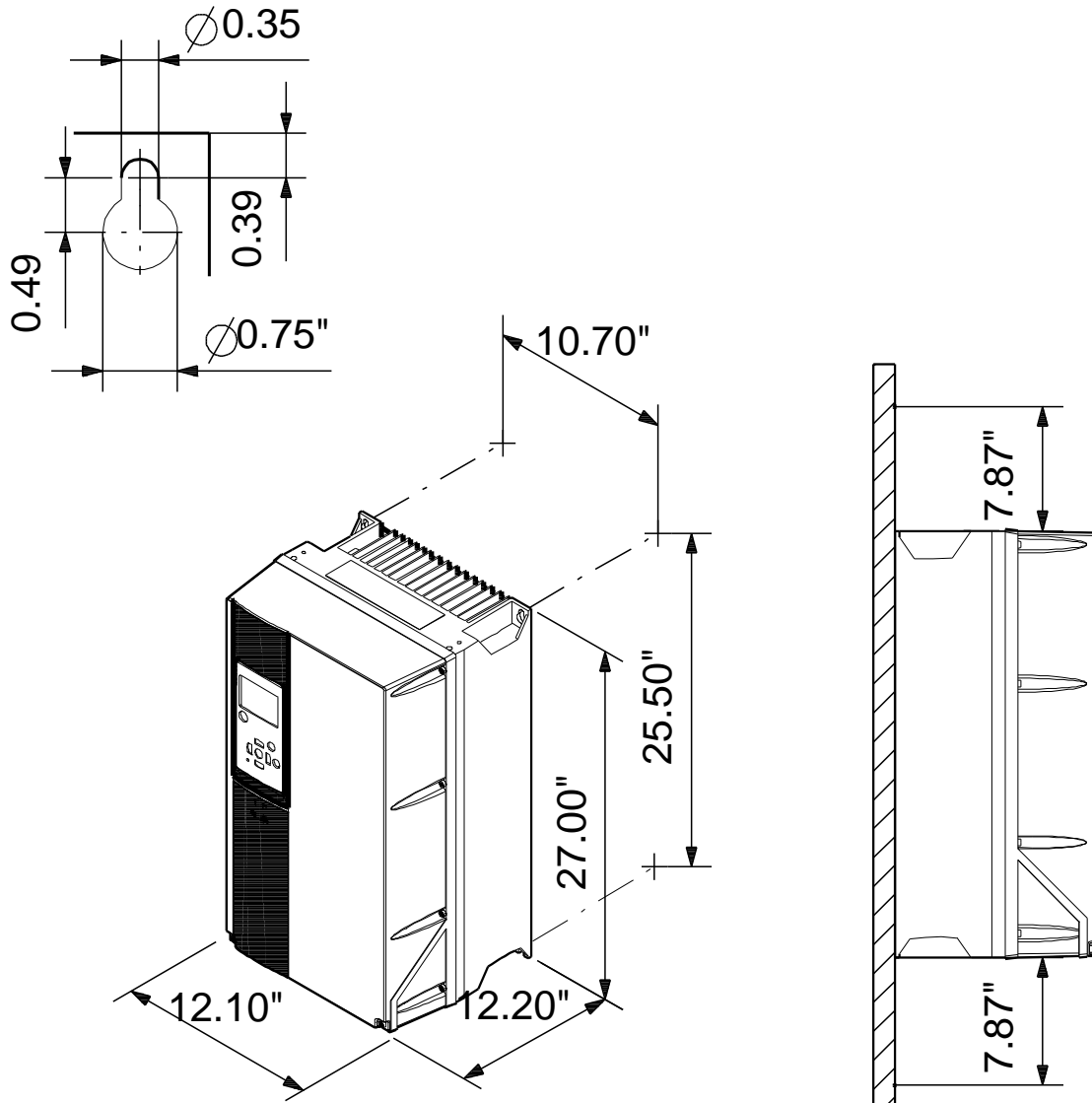

Note! All units are in [in] unless otherwise stated.
Disclaimer: This simplified dimensional drawing does not show all details.

96754729 CUE 3X380-500V IP55 45KW 90A/8 60 Hz

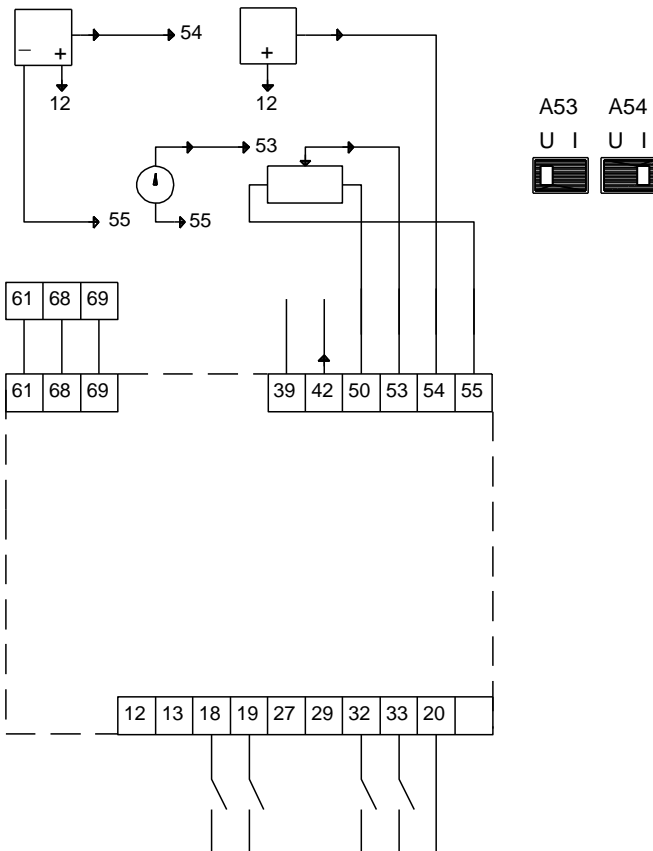
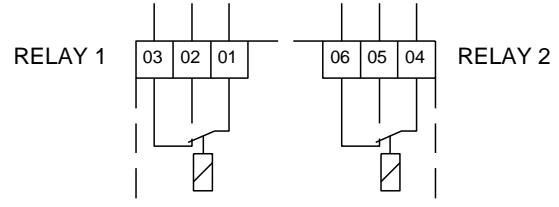
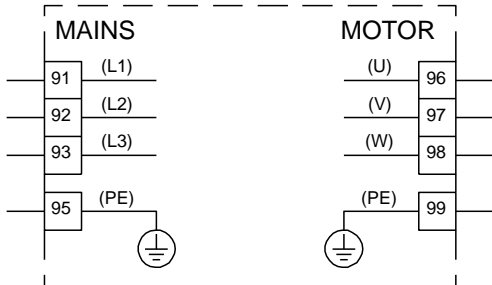

All units are [in] unless otherwise presented.